



KIESELMANN
FLUID PROCESS GROUP

Operating instructions

- Translation of the original -

Double seat valve Typ: 567x

EPDM, HNBR



ברלין טכנולוגיות בע"מ
שדרות גן רוזה 13, יבנה, 8122214
<http://www.berlintech.co.il/>
mail@berlintech.co.il
טלפון: 073-7597171
פקס: 08-6638120

1. List of contents

1.	List of contents	2
2.	Information for your safety.....	3
3.	Marking of security instructions in the operating manual	3
4.	Safety instructions	4
4.1	Field of application	4
4.2	General safety instructions	4
4.3	General notes	4
5.	Function.....	4
5.1	Functional description	4
6.	Installation informations.....	5
6.1	Installation instructions.....	5
6.2	Welding guidelines	5
7.	Maintenance	5
7.1	Maintenance	5
7.2	Cleaning flow rate	5
8.	Technical data	6
9.	Control system - and interrogation system.....	6
9.1	Special features valve control -optional-	6
9.2	Proximity switch mounting set -optional-.....	6
10.	Pneumatic valve actuation	7
11.	Disassembly and Assembly	8
11.1	Disassembly.....	8
11.2	Removing in product contact wearing parts - DN25.....	8
11.3	Assemble	8
11.4	Removing in product contact wearing parts - DN40-DN150	9
11.5	Assembly 9	
12.	Dimensions.....	10
12.1	Size measurement table	10
12.2	Dimensioned drawing	10
13.	Drawings	11
13.1	Double seat valve Type 567x.....	11
13.2	Valve insert DN25 / 1INCH	12
13.3	Valve insert DN40 - DN150 / 1½ - 4INCH.....	13
14.	Manufacturing.....	14
14.1	Structure of Article number	14
15.	Spare parts list - Double seat valve Type 567x, DN 25 / 1inch (1.4404 / AISI316L).....	16
15.1	Spare parts list - Valve insert Type 5670, DN 25 / 1INCH	16
15.2	Seal kits - Double seat valve Type 567x, DN 25 / 1INCH	17
16.	Spare parts list Double seat valve Type 567x, DN 40 - 150 / DN1 - 4INCH (1.4404 / AISI316L) ..	18
16.1	Spare parts list - Valve insert Type 5670, DN 40 - 150 / DN 1 - 4INCH.....	19
16.2	Seal kits - Double seat valve Type 567x, DN 40 - 150 / DN 1 - 4INCH	20
17.	Declaration of incorporation	21

2. Information for your safety

We are pleased that you have decided for a high-class KIESELMANN product. With correct application and adequate maintenance, our products provide long time and reliable operation.



Before installation and initiation, please carefully read this instruction manual and the security advices contained in it. This guarantees reliable and safe operation of this product and your plant respectively. Please note that an incorrect application of the process components may lead to great material damages and personal injury.

In case of damages caused by non observance of this instruction manual, incorrect initiation, handling or external interference, guarantee and warranty will lapse!

Our products are produced, mounted and tested with high diligence. However, if there is still a reason for complaint, we will naturally try to give you entire satisfaction within the scope of our warranty. We will be at your disposal also after expiration of the warranty. In addition, you will also find all necessary instructions and spare part data for maintenance in this instruction manual. If you don't want to carry out the maintenance by yourself, our KIESELMANN service team will naturally be at your disposal.

3. Marking of security instructions in the operating manual

Hints are available in the chapter "safety instructions" or directly before the respective operation instruction. The hints are highlighted with a danger symbol and a signal word. Texts beside these symbols have to be read and adhered to by all means. Please continue with the text and with the handling at the valve only afterwards.

Symbol	Signal word	Meaning
	DANGER	Imminent danger which may cause severe personal injury or death.
	ATTENTION	Dangerous situation which may cause slight personal injury or material damages.
	NOTE	Marks application hints and other information which is particularly useful.

4. Safety instructions

4.1 Field of application

Based upon its functions, the double seat valve is suitable for use in the food and beverages, in pharmaceutical, biotechnological and chemical industries. It is used mainly in combinations with several other double seat valves for the purpose of emptying and filling containers with the possibility of connecting several pipes to one tank.



ATTENTION

- To avoid danger and damage, the fitting must be used in accordance with the safety instructions and technical data contained in the operating instructions.

4.2 General safety instructions



DANGER

- Danger of crushing or amputating limbs.
Do not reach into the valve housing when in pneumatic mode.
- When removing the valve or valve components from the system, there is a danger of injury from escaping liquids or gases.
Only dismantle when you are absolutely sure that the system is depressurized and free of liquids and gases.
- Danger of scalding and burns to parts of your body from liquids escaping from the leakage drain.
The splash protection fixtures must always be attached to the leakage drain.
- The actuation can be dismantled.
Danger of injury by prestressed pressure spring. Observe separate installation instructions.
- We recommend having the manufacturer do the maintenance work required for the actuation.



ATTENTION

- To avoid air leaking, only use pneumatic connection parts that have an O-ring seal facing the even surface.
- When mounting the clamps, the max. torque must not be exceeded (see Technical data).
- Steps should be taken to ensure that no external forces are exerted on the fitting.

4.3 General notes



NOTE

All data are in line with the current state of development. Subject to change as a result of technical progress.

5. Function

5.1 Functional description

The valve is opened from bottom to top by means of control air, and is closed from top to bottom by means of spring power without any loss of product. The upper and lower valve chambers are separated during infeed in a leak-proof fashion with two, independently closed valve discs when different media flow through the valve. Leakage which occurs due to damaged valve disc seals is discharged into the atmosphere without pressure via the leakage outlet (fig. 9 /page 12 resp. fig. 10 /page 13).

6. Installation informations

6.1 Installation instructions

The valve must be installed vertically with the actuator at the upwards. Liquid must be able to flow freely from the valve housing.

6.2 Welding guidelines

Sealing elements integrated in weld components must generally be removed prior to welding.

- To prevent damage, welding should be undertaken by certified personnel (EN287).
- Use the TIG (tungsten inert gas) welding process.



NOTE

Impurities can cause damage to the seals. Clean inside areas prior to assembly.

7. Maintenance

7.1 Maintenance

The maintenance intervals depend on the operating conditions

- temperature, temperature-intervals
- medium and cleaning medium
- pressure and opening frequency

We recommend replacing the seals every 1 years. The user, however should establish appropriate maintenance intervals according to the condition of the seals.



NOTE

		<u>Lubricant recommendation</u>
EPDM; Viton; K-flex	→	Klüber Paraliq GTE*
NBR; HNBR; Silikon	→	Klüber Paraliq GB 363*
Thread	→	Teflon grease Interflon*

*) It is only permitted to use approved lubricants, if the respective fitting is used for the production of food or drink. Please observe the relevant safety data sheets of the manufacturers of lubricants.

7.2 Cleaning

Cleaning of the housing is performed with the pipe cleaning system. As part of the cleaning program, the leakage chamber and the drain pipe can be cleaned by cycling the valve discs. The valve disc shaft is also cleaned when the upper valve disc is cycled.

Alternatively, the leakage chamber and the shaft of the upper valve disc can be cleaned by means of the external rinsing connection (ESP). For cleaning the shaft, the upper valve disc has to be lifted.

7.3 Cleaning flow rate

➤ Leakage chamber - Cleaning parameters*

Cleaning step	Aerate valve disc	DIN INCH	Cleaning flow rate - clocking at the top or at the bottom (m³/h /3bar) Nominal diameter DN							
			25 1	40 1½	50 2	65 2½	80 3	100 4	125 -	150 -
Pre-Rinse	-	clocking at top	3,5	4,0	4,0	5,0	6,0	7,5	9,0	14,5
Wash 80°C	3 x 5 sec.									
Intermediate rinse	2 x 5 sec.									
Acid	3 x 5 sec.	clocking at bottom	2,0	2,5	2,5	3,0	3,0	4,5	6,0	9,0
Final rinse	2 x 5 sec.									

*.Recommended for the Beverage Industry

8. Technical data

Model:	Double seat valve	
Valve size:	DIN: DN25 - DN150 INCH: DN1 - DN4	
Connection:	Welding end DIN11850 series 2	
Temperature range:	<ul style="list-style-type: none"> • Ambient temperature: +4° - +45°C • Product temperature: +0° - +95°C medium dependent • Sterilization temperature: +140°C short time (30min) 	
Operations pressure:	DIN: DN25 - 100 = max. 10 bar DN125 - 150 = max. 6 bar INCH: DN1 - DN4 = max. 10 bar	
Pressure resistance:	40 bar	
Vacuum:	1,5 - 10 ⁻⁶ mbar x $\frac{1}{s}$ (test pressure 0,5mbar)	
Control air pressure:	5,5 - 8,0 bar	
Quality of control air:	ISO 8573-1 : 2001 quality class 3	
Material:	in product contact	not in product contact
Stainless steel:	1.4404 / AISI316L	1.4301 / AISI304
Surfaces:	RA ≤0,8µm e-pol.	metallic bright, e-pol.
Seals:	EPDM (FDA) HNBR (FDA)	NBR

Tightening moment:	Retaining clamp: nominal diameter								
Torque in Nm	DIN INCH	25 1	40 1½	50 2	65 2½	80 3	100 4	125 -	150 -
		15	15	15	25	20	55	65	65

KV-value (m³/h):	nominal diameter								
<u>Direction of flow:</u>	DIN INCH	25 1	40 1½	50 2	65 2½	80 3	100 4	125 -	150 -
transition-flow at top ⇔		26	50	95	150	240	380	580	940
transition-flow at bottom ⇔		26	55	100	155	250	390	590	940
from bottom to top ↗		16	26	45	72	98	155	245	370
from top to bottom ↘		16	24	43	67	93	150	240	330

9. Control system - and interrogation system

9.1 Special features valve control -optional-

Optionally, modular valve control systems can be installed to the actuator for reading and actuating valve positions. The standard version is a closed system with SPS or ASI-bus switch-on electronics, and integrated 3/2-way solenoid valves. For tough operating conditions we recommend employing a stainless steel hood.

9.2 Proximity switch mounting set -optional-

For the acquisition of the valve positions over inductive initiators, a limit switch support is mounted on the actuation. The enquiry takes place over the position of the piston rod.

10. Pneumatic valve actuation

Valve function	Pneum. control → with integrated (MV) in control unit (fig. 1 /page 7)	Pneum. control → with external (MV) (fig. 2 /page 7)
Valve stroke valve "OPEN"	control air feed P → MV1 → P1/LA1	control air feed ext.MV1 → LA1
Valve stroke valve "CLOSED"	de-aeration P1/LA1 → MV1 → R valve is closing by spring	de-aeration LA1 → ext.MV1 valve is closing by spring
Lower seat lift	OPEN = control air feed P → MV2 → P2/LA2	OPEN = control air feed ext.MV2 → P → LA2
	CLOSE = de-aeration P2/LA2 → MV2 → R	CLOSE = de-aeration LA2 → P → ext.MV2
Upper seat lift	OPEN = control air feed P → MV3 → P3/LA3	OPEN = control air feed ext.MV3 → LA3
	CLOSE = de-aeration P3/LA3 → MV3 → R	CLOSE = de-aeration LA3 → ext.MV3

MV = solenoid valve
 MV1 = valve stroke
 MV2 = lower seat lift
 MV3 = upper seat lift
 R = de-aeration, sound absorber
 P = compressed-air inlet (control unit)
 LA = compressed-air inlet (actuation)
 S = slide switch - manual control (solenoid valves)
 E = proximity switch M12x1
 H = proximity switch mount.

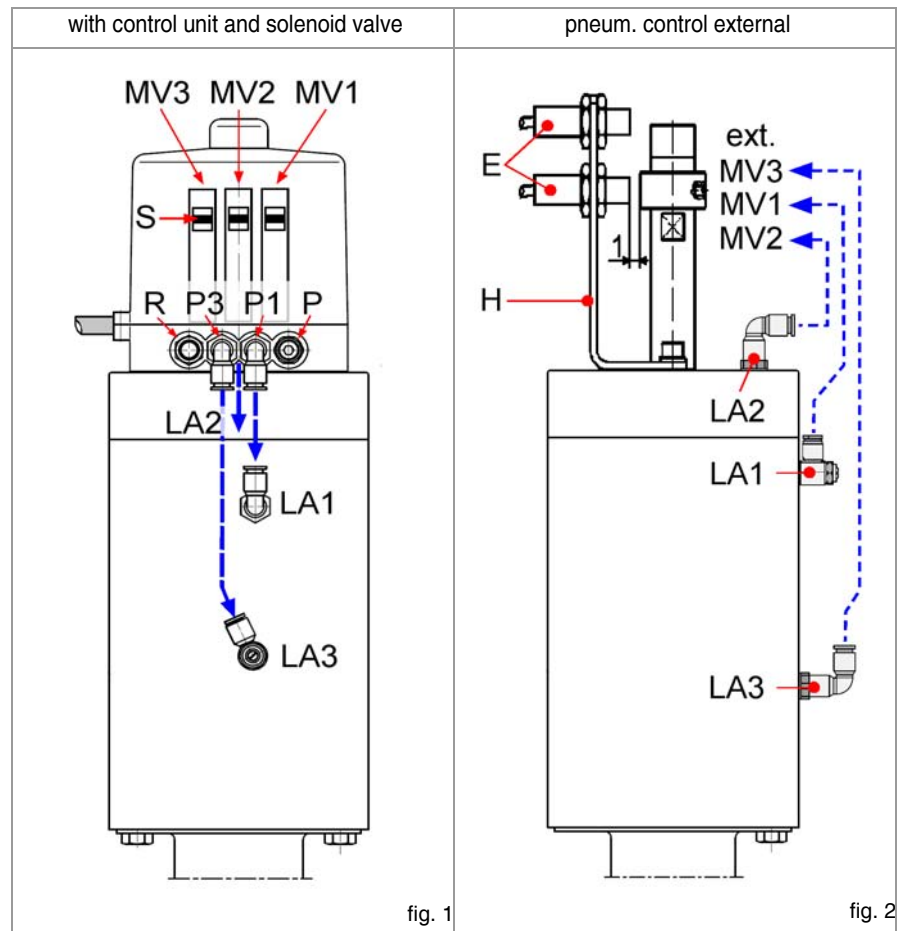

11. Disassembly and Assembly

11.1 Disassembly



NOTE

All threaded joint have right-hand thread.

Unscrew and remove control air, steam i.e. cleaning lines and electrical lines, complete proximity switch mounting or control head.

➤ Assembling tool kit

NW Article no.:
25-65 5670.065.100-000
80-100 5670.100.100-000
125-150 5670.150.100-000

socket spanner M1



eccentric socket M2



eccentric ring M3



hook wrench M4



socket spanner M5



mounting plate M6



➤ Lubricants

• EPDM; Viton; K-Flex
Klüber Paraliq GTE 703

• NBR; HNBR; Silikon
Klüber Paraliq GB 363

• Thread
Teflon grease Interflon

- Unscrew the upper retaining clamp (3).
- Remove the pneumatic valve insert, with the insert (5), the upper seal (D1) and the upper bearing bush (4) along from the top of the housing (1).
- Unscrew the lower retaining clamp (3).
- Remove the housing bottom (2) with the lower insert (5), the seal (D1) and the lower bearing bush (4).

11.2 Removing in product contact wearing parts - DN25

We recommend to use for the assembly / disassembly the assembling tool kit. (Stock number see Tab. Assembling tool kit)

- Unscrew the nut (11) and remove the disc (10).
- Separate the lower piston (6) from the upper piston (7) in axial direction.
- Take off the split washer (13).
- Unscrew the hexagon nut (14).
- Push the lantern (15) in direction 'X' until the hole (B1) is freely visible (fig. 9 /page 12).
- Place the hook spanner in the bore hole (B1) and screw out the upper piston (7) at the top with the mounting plate (see fig. 3 /page 8).
- Push off the insert (5), the upper seal (D1) and the upper bearing bush (4) of the piston (7) against direction 'X'.
- Remove the valve lift stop (16) upwards.
- Remove the seals: Item.(D1); (D2)(4x); (D4)(2x); (D5); (D8); (D9); (D10).

➤ Piston upper

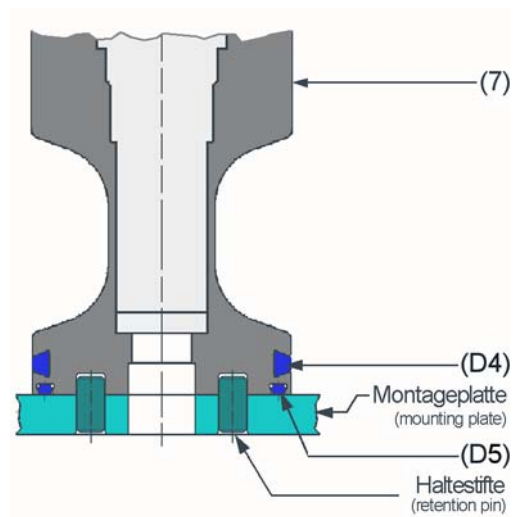

fig. 3

11.3 Assemble

Assemble in reverse order.

Thoroughly clean and slightly lubricate mounting areas and running surfaces.

➤ Assembly - seals item (D4) (2x)

- Slide the seal onto the groove.
- Place rod of approx. diameter 2 between the seal and groove in the direction of the axis.
- Remove the twist of the seal by repeated 360° rotations of the rod between seal and groove if necessary.
- Alternately press and roll the seal into the groove with round body.



NOTE

- Fit valve insert carefully into the casing. When fitting the valve insert and running surfaces onto the piston, do not damage.
- Always replace the self-locking nut (11) by a new one after unscrewing and secure it with removeable screw retention e.g. Loctite 243.
- Check valve functions by manually activating the 3/2-way solenoid valves after assembly!

11.4 Removing in product contact wearing parts - DN40-DN150

We recommend to use for the assembly / disassembly the assembling tool kit. (Stock number see Tab. Assembling tool kit)

➤ Assembling tool kit

NW Article no.:
25-65 5670.065.100-000
80-100 5670.100.100-000
125-150 5670.150.100-000

socket spanner M1



eccentric socket M2



eccentric ring M3



hook wrench M4



socket spanner M5



mounting plate M6



➤ Lubricants

• EPDM; Viton; K-Flex
Klüber Paraliq GTE 703

• NBR; HNBR; Silikon
Klüber Paraliq GB 363

• Thread
Teflon grease Interflon



11.5 Assembly

- Assemble in reverse order.
- Thoroughly clean and slightly lubricate mounting areas and running surfaces.

NOTE

- Fit valve insert carefully into the casing. When fitting the valve insert and running surfaces onto the piston, do not damage.
- Always replace the hexagon lock nut (11) by a new one after unscrewing.
- Check valve functions by manually activating the 3/2-way solenoid valves after assembly.

➤ Assembly - seals item (D4) (2x)

- Screw in piston plate (8) resp. (9) without the seal (D4) to the metal limit stop in the piston (6) resp. (7) and make a coloured mark (fig. 6 /page 9).
- Screw out the piston plate (8) resp. (9) of the piston (6) resp. (7).
- Push the seal (D4) into the piston (6) resp. (7) and screw the piston plate (8) resp. (9) into the pistons (6) resp. (7) by hand.
- Position the eccentric ring (M3) on the seal (D4) (fig. 5 /page 9).
- Clamp the mounting plate into the vice and fix the piston plate (8) resp. (9) (see fig. 4 /page 9 resp. fig. 5 /page 9).
- Position the socket spanner M1 resp. M5 and screw the piston (6) resp. (7) up to the final limit mark (fig. 6 /page 9).

➤ Piston lower

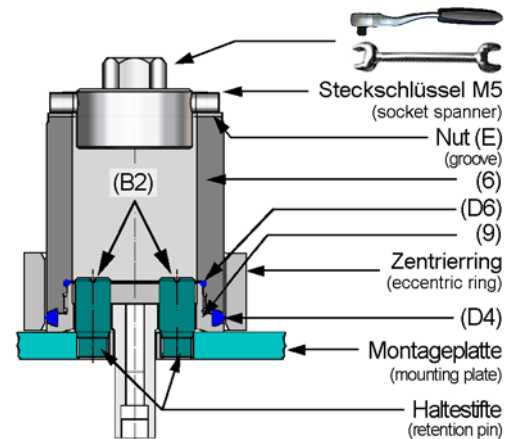

fig. 4

➤ Piston upper

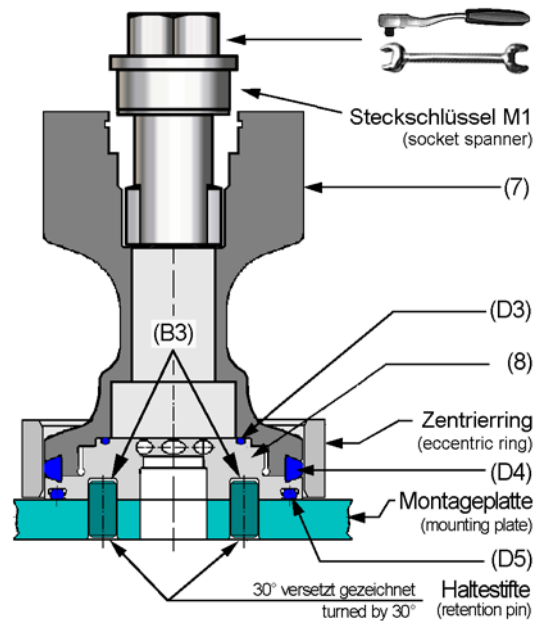

fig. 5

➤ Mark

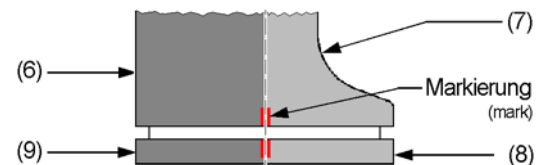

fig. 6

12. Dimensions

12.1 Size measurement table

	DIN INCH	25 1	40 1½	50 2	65 2½	80 3	100 4	125 -	150 -
D1	DIN INCH	ø 29x1,5 ø 25,4x1,65	ø 41x1,5 ø 38,1x1,65	ø 53x1,5 ø 50,8x1,65	ø 70x2 ø 63,5x1,65	ø 85x2 ø 76,2x1,65	ø 104x2 ø 101,6x2,11	ø 129x2 -	ø 154x2 -
D2	DIN INCH	ø 29x1,5 ø 25,4x1,65	ø 41x1,5 ø 38,1x1,65	ø 53x1,5 ø 50,8x1,65	ø 70x2 ø 63,5x1,65	ø 85x2 ø 76,2x1,65	ø 104x2 ø 101,6x2,11	ø 129x2 -	ø 154x2 -
D3	DIN INCH	ø 128 ø 128	ø 128 ø 128	ø 128 ø 128	ø 128 ø 128	ø 160 ø 160	ø 160 ø 160	ø 230 -	ø 230 -
D4	- Standard rinsing connection: screwed socket DN15 DIN11851 - Rinsing connection: M14x1,5 with cutting ring union for tube 8x1								
L1	DIN INCH	150 150	170 170	170 170	210 210	230 230	260 260	320 -	345 -
L2	DIN INCH	118 112,1	132 127,4	154 151,3	181 189,1	228 223,4	264 264,7	315 -	337 -
L3	DIN INCH	46 42	59 56	72 68,5	87 81	106 98	125 122	150 -	175 -
L4	DIN INCH	448 448	447 447	446 446	464 464	531 531	560 560	615 -	628 -
L5	DIN INCH	- -	- -	- -	172 -	192,5 -	232 -	- -	- -

size when completed

with control head	L6	DIN INCH	600 600	600 600	630 630	680 680	790 790	860 860	960 -	1015 -
without control head	L6	DIN INCH	590 590	590 590	620 620	670 670	780 780	850 850	950 -	1005 -
with control head	L7	DIN INCH	- -	- -	- -	953 -	1079 -	1184 -	- -	- -
without control head	L7	DIN INCH	- -	- -	- -	818 -	944 -	1049 -	- -	- -

12.2 Dimensioned drawing

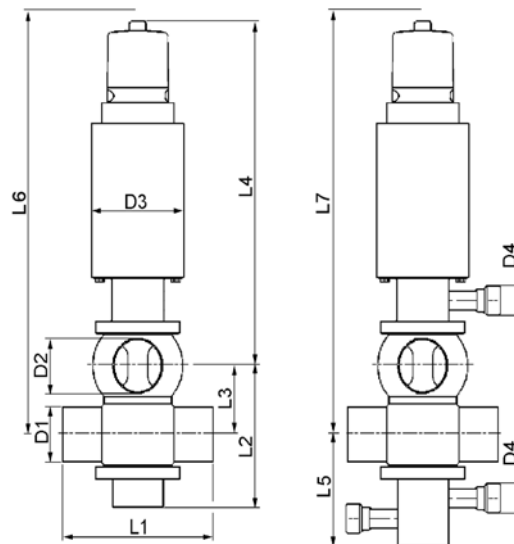

fig. 7

13. Drawings

13.1 Double seat valve Type 567x

- A1 = Control head
- A2 = Proximity switch mount.
- VE = Valve insert
- 1 = Valve housing
 - S-S
 - SS-S
 - S-SS
 - SS-SS
- 2a = Housing bottom
- 2b = Housing bottom with rinsing connection
- 3 = Retaining clamp
- 4 = Bearing bush
- 5 = Housing insert
- 15a = Lantern
- 15b = Lantern with rinsing connection
- 21 = Screwed socket

- D1 = Seal
- D2 = O-Rings
- D11 = O-Rings
- D12 = O-Rings

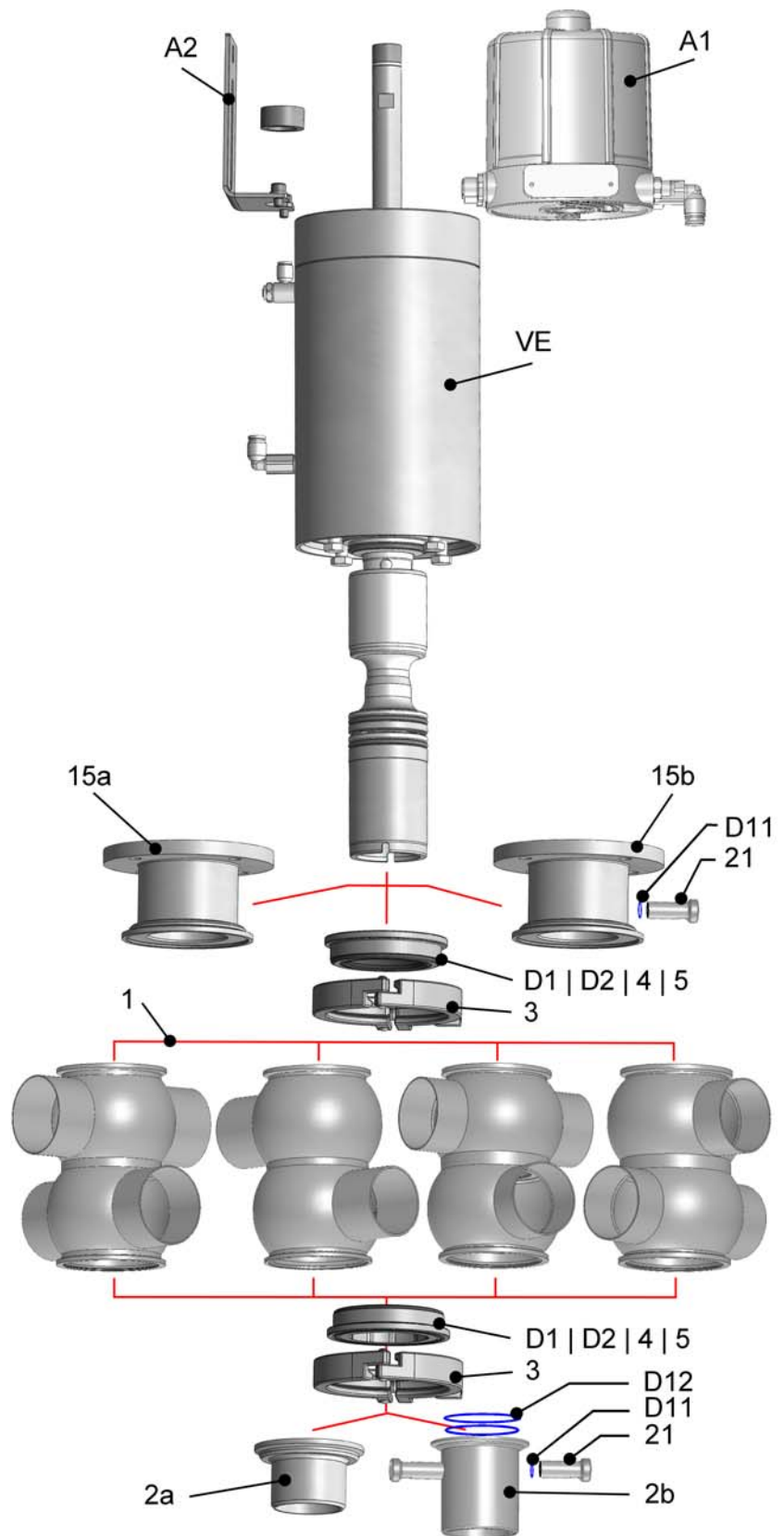

fig. 8

13.2 Valve insert DN25 / 1INCH

- 1) -
- 2) -
- 3) Retaining clamp
- 4) Bearing bush
- 5) Housing insert
- 6) Piston lower
- 7) Piston upper
- 8) -
- 9) -
- 10) Disc
- 11) Hexagon nut
- 12) Plain bearing
- 13) Split washer
- 14) Hexagon screw
- 15) Lantern
- 16) Valve lift stop
- 17) pneum. actuator
- 18) Position indication red
- 19) O-Ring
- 20) Screwed cap

Seal kit

- D1) Seal (2x)
- D2) O-Ring (4x)
- D3) -
- D4) Seal (2x)
- D5) O-Ring
- D6) -
- D7) Headless pin
- D8) O-Ring (2x)
- D9) O-Ring
- D10) O-Ring

- B = Bore
- E = Slot
- X = Leakage tell taue
- IG = Puls generator
- M = Magnets

G1 = Lock nut high strength
(e.g. Loctite 2701)

- LA1 = Main valve lift
- LA2 = Lower seat lift
- LA3 = Upper seat lift
- Y = Detail

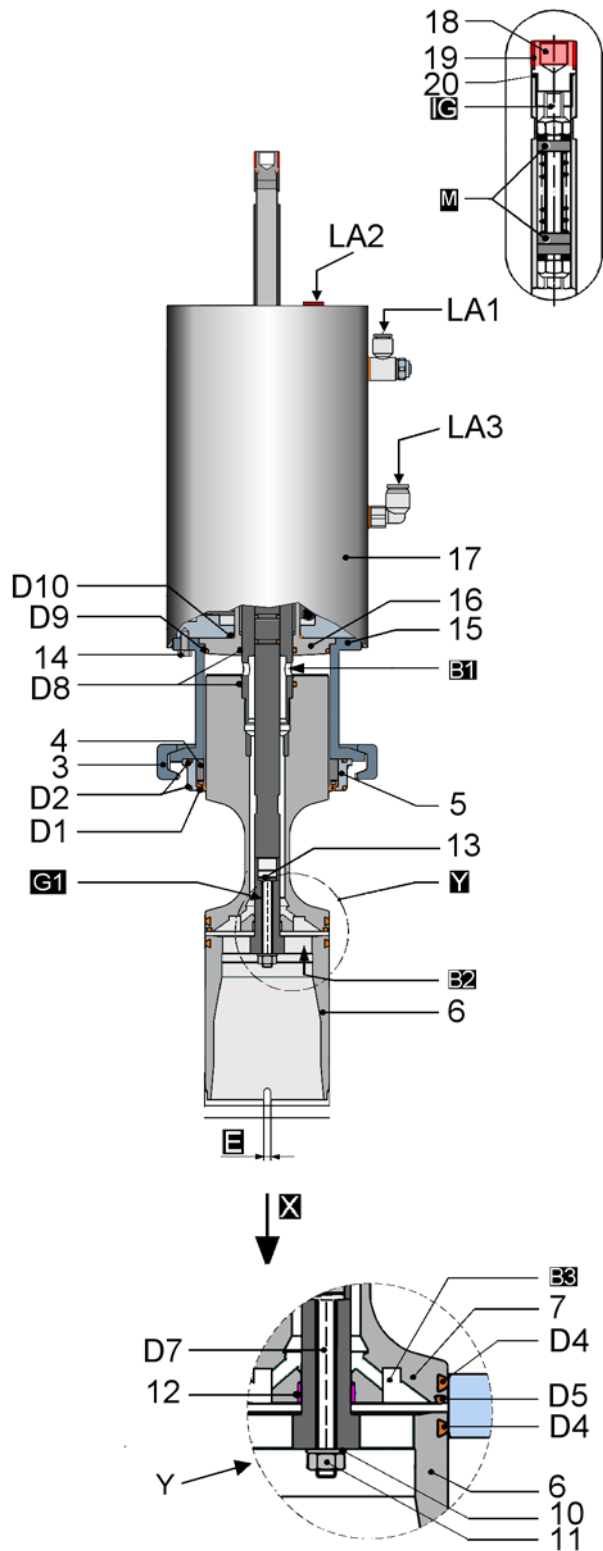

fig. 9

13.3 Valve insert DN40 - DN150 / 1½ - 4INCH

- 1) -
- 2) -
- 3) Retaining clamp
- 4) Bearing bush
- 5) Housing insert
- 6) Piston lower
- 7) Piston upper
- 8) Piston plate upper
- 9) Piston plate lower
- 10) Disc
- 11) Hexagon nut
- 12) Plain bearing
- 13) Split washer
- 14) Hexagon screw
- 15) Lantern
- 16) Valve lift stop
- 17) pneum. actuator
- 18) Position indication red
- 19) O-Ring
- 20) Screwed cap

Seal kit

- D1) Seal (2x)
- D2) O-Ring (4x)
- D3) O-Ring
- D4) Seal (2x)
- D5) O-Ring
- D6) O-Ring
- D7) Headless pin
- D8) O-Ring (2x)
- D9) O-Ring
- D10) O-Ring

- B = Bore
- E = Slot
- X = Leakage tell taue
- IG = Puls generator
- M = Magnets

G1 = Lock nut high strength
(e.g. Loctite 2701)

LA1 = Main valve lift

LA2 = Lower seat lift

LA3 = Upper seat lift

Y = Detail

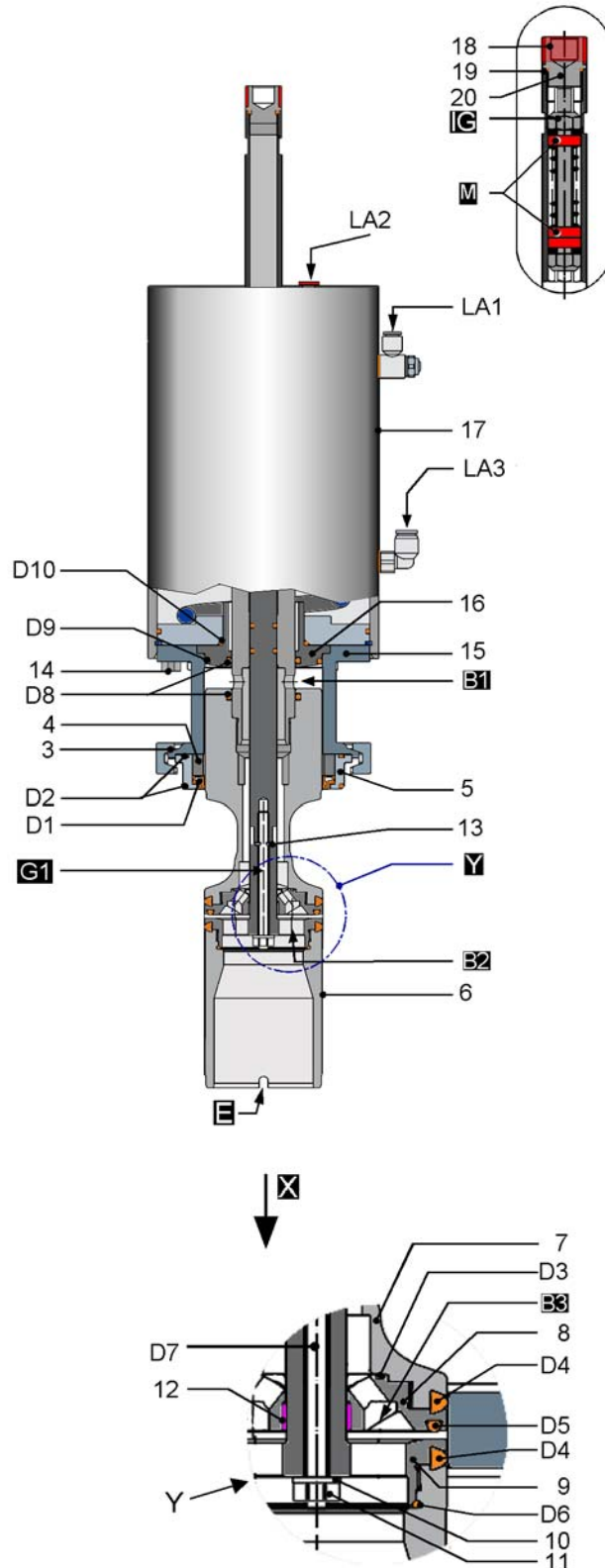
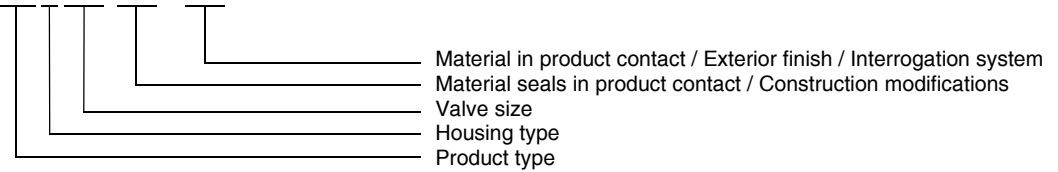

fig. 10

14. Manufacturing

14.1 Structure of Article number

5674 050 730 - 041



➤ Product type

Double seat valve Type 567x

➤ Housing type

5670

Valve without housing

5671 SS-S



5672 S-S



5673 S-SS



5674 SS-SS



➤ Valve size

DN = Nominal diameter

DIN	025 = DN25	040 = DN50	050 = DN50	065 = DN65	080 = DN80	100 = DN100	125 = DN125	150 = DN150
INCH	026 = DN1	038 = DN1½	051 = DN2	064 = DN2½	076 = DN3	101 = DN4	-	-

➤ Material seal / Construction modifications

Material seals in product contact: EPDM, HNBR, NBR, Viton, Silikon, k-flex

Construction modifications: external rinsing connection upper / lower

➤ Material in product contact / Exterior finish

020 - 1.4301/1.4307 AISI304/307 - bright turned	040 - 1.4301/1.4307 AISI304/307 - bright turned
021 - 1.4301/1.4307 AISI304/307 - E-polished	041 - 1.4301/1.4307 AISI304/307 - E-polished
022 - 1.4301/1.4307 AISI304/307 - unpolished, glass-bead blasted	042 - 1.4301/1.4307 AISI304/307 - unpolished, glass-bead blasted

➤ Interrogation system

Article Number	Control System or Interrogation System (A1, A2)					Pulse Generator IG	
56xx DN xxx	-041	-	-----	-	-	Valve without Control- or Interrogation System	-----
56xx DN xxx	-750	Mounting	5630 005 000-020	-	-	Valve with Sensor Mounting Set	-----

Control Head ASI-Bus Double Seat Valve

56xx DN xxx	-600	Control head	5630 200 000-000	ASI-Bus Standard	0 MV	ASI 2-wire cable adapter	5620 DN 005-000
56xx DN xxx	-601	Control head	5630 201 000-000	ASI-Bus Standard	1 MV	ASI 2-wire cable adapter	5620 DN 005-000
56xx DN xxx	-602	Control head	5630 202 000-000	ASI-Bus Standard	2 MV	ASI 2-wire cable adapter	5620 DN 005-000
56xx DN xxx	-603	Control head	5630 203 000-000	ASI-Bus Standard	3 MV	ASI 2-wire cable adapter	5620 DN 005-000
56xx DN xxx	-604	Control head	5630 203 010-000	ASI-Bus/ES/ABSL	3 MV	Plug M12 4-pin / plug socket M12 5-pin	5620 DN 005-000
56xx DN xxx	-605	Control head	5630 203 051-000	ASI-Bus/ABSL	3 MV	Plug M12 4-pin, ES-LA	5620 DN 005-000
56xx DN xxx	-606	Control head	5630 201 010-000	ASI-Bus/ES/ABSL	1 MV	Plug M12 4-pin / plug socket M12 5-pin	5620 DN 005-000
56xx DN xxx	-609	Control head	5630 203 050-000	ASI-Bus/ABSL	3 MV	Plug M12 4-pin	5620 DN 005-000
56xx DN xxx	-610	Control head	5630 202 010-000	ASI-Bus/ES/ABSL	2 MV	Plug M12 4-pin / plug socket M12 5-pin	5620 DN 005-000
56xx DN xxx	-611	Control head	5630 201 051-000	ASI-Bus/ABSL	1 MV	Plug M12 4-pin, ES-LA	5620 DN 005-000
56xx DN xxx	-613	Control head	5630 202 051-000	ASI-Bus/ABSL	2 MV	Plug M12 4-pin, ES-LA	5620 DN 005-000
56xx DN xxx	-614	Control head	5630 203 053-000	ASI-Bus/ABSL	3 MV	ASI 2-wire cable adapter	5620 DN 005-000
56xx DN xxx	-615	Control head	5630 203 003-000	ASI-Bus Standard	3 MV	KV M16x1,5 / Pg 9	5620 DN 005-000
56xx DN xxx	-616	Control head	5630 201 003-000	ASI-Bus Standard	1 MV	KV M16x1,5 / Pg 9	5620 DN 005-000
56xx DN xxx	-619	Control head	5630 203 151-000	ASI-Bus/ABSL	3 MV	Plug M12 4-pin, LED-ESH	5620 DN 005-000
56xx DN xxx	-620	Control head	5630 201 050-000	ASI-Bus/ABSL	1 MV	Plug M12 4-pin	5620 DN 005-000
56xx DN xxx	-624	Control head	5630 202 050-000	ASI-Bus/ABSL	2 MV	Plug M12 4-pin	5620 DN 005-000
56xx DN xxx	-625	Control head	5630 201 158-000	ASI-Bus/ABSL	1 MV	KV M16x1,5, LED-ESH	5620 DN 005-000
56xx DN xxx	-626	Control head	5630 202 158-000	ASI-Bus/ABSL	2 MV	KV M16x1,5, LED-ESH	5620 DN 005-000
56xx DN xxx	-627	Control head	5630 203 158-000	ASI-Bus/ABSL	3 MV	KV M16x1,5, LED-ESH	5620 DN 005-000
56xx DN xxx	-628	Control head	5630 201 151-000	ASI-Bus/ABSL	1 MV	Plug M12 4-pin, LED-ESH	5620 DN 005-000
56xx DN xxx	-629	Control head	5630 201 151-000	ASI-Bus/ABSL	1 MV	Plug M12 4-pin, LED-ESH, ES-LA	5620 DN 005-000
56xx DN xxx	-630	Control head	5630 200 061-000	ASI-Bus Standard	0 MV	Plug M12 4-pin	5620 DN 005-000
56xx DN xxx	-631	Control head	5630 201 061-000	ASI-Bus Standard	1 MV	Plug M12 4-pin	5620 DN 005-000
56xx DN xxx	-632	Control head	5630 202 061-000	ASI-Bus Standard	2 MV	Plug M12 4-pin	5620 DN 005-000
56xx DN xxx	-633	Control head	5630 203 061-000	ASI-Bus Standard	3 MV	Plug M12 4-pin	5620 DN 005-000
56xx DN xxx	-640	Control head	5630 201 058-000	ASI-Bus/ABSL	1 MV	KV 2x M16x1,5	5620 DN 005-000
56xx DN xxx	-641	Control head	5630 202 058-000	ASI-Bus/ABSL	2 MV	KV 2x M16x1,5	5620 DN 005-000
56xx DN xxx	-642	Control head	5630 203 058-000	ASI-Bus/ABSL	3 MV	KV 2x M16x1,5	5620 DN 005-000
56xx DN xxx	-681	Control head	5630 203 081-000	ASI-Bus100/ABSL	3 MV	Plug M12 4-pin, Position Indicator, ES-LA	5620 DN 005-000
56xx DN xxx	-682	Control head	5630 203 080-000	ASI-Bus100/ABSL	3 MV	Plug M12 4-pin, Position Indicator	5620 DN 005-000

Control Head SPS Double Seat Valve

56xx DN xxx	-500	Control head	5630 000 000-000	SPS-Standard	0 MV	KV M16x1,5 / Pg 9	5620 DN 005-000
56xx DN xxx	-501	Control head	5630 001 000-000	SPS-Standard	1 MV	KV M16x1,5 / Pg 9	5620 DN 005-000
56xx DN xxx	-502	Control head	5630 002 000-000	SPS-Standard	2 MV	KV M16x1,5 / Pg 9	5620 DN 005-000
56xx DN xxx	-503	Control head	5630 003 000-000	SPS-Standard	3 MV	KV M16x1,5 / Pg 9	5620 DN 005-000
56xx DN xxx	-505	Control head	5630 001 108-000	SPS-Standard	1 MV	KV 2x M16x1,5 / Pg 9, LED-ESH	5620 DN 005-000
56xx DN xxx	-506	Control head	5630 002 108-000	SPS-Standard	2 MV	KV 2x M16x1,5 / Pg 9, LED-ESH	5620 DN 005-000
56xx DN xxx	-507	Control head	5630 003 108-000	SPS-Standard	3 MV	KV 2x M16x1,5 / Pg 9, LED-ESH	5620 DN 005-000
56xx DN xxx	-508	Control head	5630 001 100-000	SPS-Standard	1 MV	KV M16x1,5 / Pg 9, ESH	5620 DN 005-000
56xx DN xxx	-510	Control head	5630 000 040-000	SPS-Standard	0 MV	KV M16x1,5 / Pg 9, Valve tag	5620 DN 005-000
56xx DN xxx	-513	Control head	5630 003 040-000	SPS-Standard	3 MV	KV M16x1,5 / Pg 9, Valve tag	5620 DN 005-000
56xx DN xxx	-582	Control head	5630 003 080-000	SPS-Standard	3 MV	KV M16x1,5 / Pg 9, Position Indicator	5620 DN 005-000

DN - Nominal Diameter z.B. 5674 050 730-041
 MV - Solenoid Valve
 KV - Compression Gland 4,5-6mm
 ESH - Stainless Steel Cap
 ES-LA - Stainless Steel -Air Connection

15. Spare parts list - Double seat valve Type 567x, DN 25 / 1inch (1.4404 / AISI316L)

Housing type	Seal	Article number	VE Valve insert	Seal kit	Item.1 Housing						
<i>Standard</i>											
SS - S S - S S - SS SS - SS	EPDM	5671 DN 130 - xxx 5672 DN 130 - xxx 5673 DN 130 - xxx 5674 DN 130 - xxx	5670 DN 130-041	5670 025 130-000	5621 DN 001-041 5622 DN 001-041 5623 DN 001-041 5624 DN 001-041						
SS - S S - S S - SS SS - SS		HNBR			5671 DN 420 - xxx 5672 DN 420 - xxx 5673 DN 420 - xxx 5674 DN 420 - xxx	5670 DN 420-041	5670 025 420-000	5621 DN 001-041 5622 DN 001-041 5623 DN 001-041 5624 DN 001-041			
<i>ext. rinsing connection upper</i>											
SS - S S - S S - SS SS - SS					EPDM			5671 DN 760 - xxx 5672 DN 760 - xxx 5673 DN 760 - xxx 5674 DN 760 - xxx	5670 DN 760-041	5670 025 769-000	5621 DN 001-041 5622 DN 001-041 5623 DN 001-041 5624 DN 001-041
SS - S S - S S - SS SS - SS	HNBR		5671 DN 770 - xxx 5672 DN 770 - xxx 5673 DN 770 - xxx 5674 DN 770 - xxx	5670 DN 770-041				5670 025 779-000			5621 DN 001-041 5622 DN 001-041 5623 DN 001-041 5624 DN 001-041
<i>rinsing connection: M14x1,5 with cutting ring union for tube 8x1</i>											
SS - S S - S S - SS SS - SS		EPDM	5671 DN 762 - xxx 5672 DN 762 - xxx 5673 DN 762 - xxx 5674 DN 762 - xxx			5670 DN 762-041	5670 025 769-000				5621 DN 001-041 5622 DN 001-041 5623 DN 001-041 5624 DN 001-041
SS - S S - S S - SS SS - SS			HNBR		5671 DN 772 - xxx 5672 DN 772 - xxx 5673 DN 772 - xxx 5674 DN 772 - xxx				5670 DN 772-041	5670 025 779-000	5621 DN 001-041 5622 DN 001-041 5623 DN 001-041 5624 DN 001-041

DDN- Nominal diameter e.g. 5674 050 730-041

xxx - Material in product contact / Exterior finish / Interrogation system (see Tab. Interrogation system)

S - Welding end

Item	Designation	Material	DN25 / 1INCH
2	Housing bottom	AISI303	5671 025 008-220
3	Retaining clamp (2x)	AISI304	2122 065 100-020
4	Bearing bush lower	PTFE	5622 050 006-053
5	Housing insert lower	AISI316L	5672 025 004-040
D1	Seal (included in seal kit)	EPDM HNBR	5622 050 010-069 5622 050 010-050
D2	O-Ring (2x) (included in seal kit)	EPDM HNBR	2304 069 026-159 2304 069 026-050

15.1 Spare parts list - Valve insert Type 5670, DN 25 / 1INCH

Item	Designation	Material	DN25	1INCH
VE	Valve insert (a) Standard	EPDM HNBR	5670 025 130-041 5670 025 420-041	5670 026 130-041 5670 026 420-041
VE	Valve insert (b) ext. rinsing connection upper	EPDM HNBR	5670 025 760-041 5670 025 770-041	5670 026 760-041 5670 026 770-041
VE	Valve insert (c) rinsing connection: M14x1,5 with cutting ring union for tube 8x1	EPDM HNBR	5670 025 762-041 5670 025 772-041	5670 026 762-041 5670 026 772-041
4	Bearing bush upper	PTFE	5622 050 006-053	
5	Housing insert upper	AISI316L	5672 025 004-040	
6	Piston lower	AISI316L	5671 025 005-040	
7	Piston upper	AISI316L	5622 025 003-040	
8	-	-	-	
9	-	-	-	
10	Disc	AISI304	8071 064 001-020	
11	Hexagon nut	AISI304	8113 006 000-020	
12	Plain bearing	XMS	8050 015 007-156	
13	Split washer	AISI304	8140 006 001-020	
14	Hexagon screw	AISI304	8106 008 016-020	
15	Lantern Valve insert (a) Lantern compl. - Valve insert (b) Lantern compl. - Valve insert (c)	AISI304 AISI304 AISI304	5624 040 008-021 5624 040 515-021 5624 040 517-021	
16	Valve lift stop	AISI303	5622 025 009-220	
17	Pneum. actuator	AISI304	5620 065 000-021	
18	Position indication red	PVC	5622 100 058-151	
19	O-Ring	NBR	2304 012 020-055	
20	Screwed cap	AISI303	5622 100 071-220	
21	Screwed socket	AISI303	5624 065 514-020	
LA1	One-way restrictor	-	8218 001 020-000	
LA3	Rapid action hose coupling	-	8217 000 004-000	

15.2 Seal kits - Double seat valve Type 567x, DN 25 / 1INCH

Item	Designation	Material	DN25 / 1INCH
	Seal kit EPDM (A)	EPDM	5670 025 130-000
	Seal kit EPDM (B) - rinsing connection upper	EPDM	5670 025 769-000
D1	Seal (2x)	EPDM	5622 050 010-069
D2	O-Ring (4x)	EPDM	2304 069 026-159
D3	-	-	-
D4	O-Ring (2x)	EPDM	2304 047 035-159
D5	O-Ring	EPDM	2304 041 035-159
D6	-	-	-
D7	Headless pin	AISI304	8112 006 040-020
D8	O-Ring (2x)	EPDM	2304 036 035-159
D9	O-Ring	EPDM	2304 047 035-159
D10	O-Ring	HNBR	2304 042 025-055
D11	O-Ring (seal kit B)	EPDM	2304 014 020-170
11	Hexagon nut	AISI304	8113 006 000-020

Item	Designation	Material	DN25 / 1INCH
	Seal kit HNBR (A)	HNBR	5670 025 420-000
	Seal kit HNBR (B) - rinsing connection upper	HNBR	5670 025 779-000
D1	Seal (2x)	HNBR	5622 050 010-050
D2	O-Ring (4x)	HNBR	2304 069 026-050
D3	-	-	-
D4	O-Ring (2x)	HNBR	2304 047 035-157
D5	O-Ring	HNBR	2304 041 035-157
D6	-	-	-
D7	Headless pin	AISI304	8112 006 040-020
D8	O-Ring (2x)	EPDM	2304 036 035-159
D9	O-Ring	EPDM	2304 047 035-159
D10	O-Ring	NBR	2304 042 025-055
D11	O-Ring (seal kit B)	EPDM	2304 014 020-170
11	Hexagon nut	AISI304	8113 006 000-020

16. Spare parts list Double seat valve Type 567x, DN 40 - 150 / DN1 - 4INCH (1.4404 / AISI316L)

Housing type	Seal	Article number	VE Valve insert	Seal kit	Item.1 Housing	Item. 2 Housing bottom							
<i>Standard</i>					AISI316L	AISI303							
SS - S S - S S - SS SS - SS	EPDM	5671 DN 730-xxx 5672 DN 730-xxx 5673 DN 730-xxx 5674 DN 730-xxx	5670 DN 730-041	5670 DN 739-000	5621 DN 001-041 5622 DN 001-041 5623 DN 001-041 5624 DN 001-041	5671 DN 008-220							
SS - S S - S S - SS SS - SS		HNBR			5671 DN 720-xxx 5672 DN 720-xxx 5673 DN 720-xxx 5674 DN 720-xxx		5670 DN 720-041	5670 DN 729-000	5621 DN 001-041 5622 DN 001-041 5623 DN 001-041 5624 DN 001-041				
<i>ext. rinsing connection upper</i>													
SS - S S - S S - SS SS - SS					EPDM				5671 DN 760-xxx 5672 DN 760-xxx 5673 DN 760-xxx 5674 DN 760-xxx	5670 DN 760-041	5670 DN 769-000	5621 DN 001-041 5622 DN 001-041 5623 DN 001-041 5624 DN 001-041	5671 DN 008-220 complete with Item 21 and D11
SS - S S - S S - SS SS - SS	HNBR		5671 DN 770-xxx 5672 DN 770-xxx 5673 DN 770-xxx 5674 DN 770-xxx	5670 DN 770-041		5670 DN 779-000			5621 DN 001-041 5622 DN 001-041 5623 DN 001-041 5624 DN 001-041				
<i>rinsing connection: M14x1,5 with cutting ring union for tube 8x1</i>													
SS - S S - S S - SS SS - SS		EPDM	5671 DN 762-xxx 5672 DN 762-xxx 5673 DN 762-xxx 5674 DN 762-xxx				5670 DN 762-041	5670 DN 769-000	5621 DN 001-041 5622 DN 001-041 5623 DN 001-041 5624 DN 001-041			5671 DN 008-220 complete with Item 21 and D11	
SS - S S - S S - SS SS - SS			HNBR		5671 DN 772-xxx 5672 DN 772-xxx 5673 DN 772-xxx 5674 DN 772-xxx				5670 DN 772-041	5670 DN 779-000	5621 DN 001-041 5622 DN 001-041 5623 DN 001-041 5624 DN 001-041		
<i>ext. rinsing connection lower</i>													
SS - S S - S S - SS SS - SS	EPDM			5671 DN 793-xxx 5672 DN 793-xxx 5673 DN 793-xxx 5674 DN 793-xxx	5670 DN 793-041	5670 DN 799-000					5621 DN 001-041 5622 DN 001-041 5623 DN 001-041 5624 DN 001-041		5676 DN 023-220 complete with Item 21 and D11
SS - S S - S S - SS SS - SS		HNBR		5671 DN 792-xxx 5672 DN 792-xxx 5673 DN 792-xxx 5674 DN 792-xxx			5670 DN 792-041	5670 DN 798-000			5621 DN 001-041 5622 DN 001-041 5623 DN 001-041 5624 DN 001-041		

DN = Nominal diameter e.g. 5674 050 730-041

xxx = Material in product contact / Exterior finish / Interrogation system (see Tab. Interrogation system)

S = Welding end

Item	Designation	Material	DN40 1½INCH	DN50 2INCH	DN65 2½INCH	DN80 3INCH	DN100 4INCH	DN125 -	DN150 -
3	Retaining clamp (2x)	AISI304	2122 065 100-020	2122 065 100-020	2122 080 100-020	2122 115 100-020	2122 125 100-020	2122 150 100-020	2122 200 100-020
4	Bearing bush lower	PTFE	5622 050 006-053	5622 050 006-053	5622 065 006-053	5622 080 006-053	5622 100 006-053	5622 125 006-053	5622 150 006-053
5	Housing insert lower	AISI316L	5622 050 005-040	5622 050 005-040	5622 065 005-040	5622 080 005-040	5622 100 005-040	5622 125 005-040	5622 150 005-040
D1	Seal (included in seal kit)	EPDM	5622 050 010-069	5622 050 010-069	5622 065 010-069	5622 080 010-069	5622 100 010-069	5622 125 010-069	5622 150 010-069
		HNBR	5622 050 010-050	5622 050 010-050	5622 065 010-050	5622 080 010-050	5622 100 010-050	5622 125 010-050	5622 150 010-050
D2	O-Ring (2x) (included in seal kit)	EPDM	2304 069 026-159	2304 069 026-159	2304 082 026-159	2304 098 035-159	2304 117 035-159	2304 142 035-159	2304 177 035-170
		HNBR	2304 069 026-050	2304 069 026-050	2304 082 026-050	2304 098 035-050	2304 117 035-050	2304 142 035-050	2304 177 035-050

16.1 Spare parts list - Valve insert Type 5670, DN 40 - 150 / DN 1 - 4INCH

Item	Designation	Material	DN40 1½INCH	DN50 2INCH	DN65 2½INCH	DN80 3INCH	DN100 4INCH	DN125 -	DN150 -
VE	Valve insert (a) - DIN - Standard	EPDM HNBR	5670 040 730-041 5670 040 720-041	5670 050 730-041 5670 050 720-041	5670 065 730-041 5670 065 720-041	5670 080 730-041 5670 080 720-041	5670 100 730-041 5670 100 720-041	5670 125 730-041 5670 125 720-041	5670 150 730-041 5670 150 720-041
VE	Valve insert (b) - DIN - ext. rinsing connection upper	EPDM HNBR	5670 040 760-041 5670 040 770-041	5670 050 760-041 5670 050 770-041	5670 065 760-041 5670 065 770-041	5670 080 760-041 5670 080 770-041	5670 100 760-041 5670 100 770-041	5670 125 760-041 5670 125 770-041	5670 150 760-041 5670 150 770-041
VE	Valve insert (c) - DIN - rinsing connection: M14x1,5 with cutting ring union for tube 8x1	EPDM HNBR	5670 040 762-041 5670 040 772-041	5670 050 762-041 5670 050 772-041	5670 065 762-041 5670 065 772-041	5670 080 762-041 5670 080 772-041	5670 100 762-041 5670 100 772-041	5670 125 762-041 5670 125 772-041	5670 150 762-041 5670 150 772-041
VE	Valve insert (d) - DIN - ext. rinsing connection lower	EPDM HNBR	5670 040 793-041 5670 040 792-041	5670 050 793-041 5670 050 792-041	5670 065 793-041 5670 065 792-041	5670 080 793-041 5670 080 792-041	5670 100 793-041 5670 100 792-041	5670 125 793-041 5670 125 792-041	5670 150 793-041 5670 150 792-041
VE	Valve insert (a) - INCH - Standard	EPDM HNBR	5670 038 730-041 5670 038 720-041	5670 051 730-041 5670 051 720-041	5670 064 730-041 5670 064 720-041	5670 076 730-041 5670 076 720-041	5670 101 730-041 5670 101 720-041	-	-
VE	Valve insert (b) - INCH - ext. rinsing connection upper	EPDM HNBR	5670 038 760-041 5670 038 770-041	5670 051 760-041 5670 051 770-041	5670 064 760-041 5670 064 770-041	5670 076 760-041 5670 076 770-041	5670 101 760-041 5670 101 770-041	-	-
VE	Valve insert (c) - INCH - rinsing connection: M14x1,5 with cutting ring union for tube 8x1	EPDM HNBR	5670 038 762-041 5670 038 772-041	5670 051 762-041 5670 051 772-041	5670 064 762-041 5670 064 772-041	5670 076 762-041 5670 076 772-041	5670 101 762-041 5670 101 772-041	-	-
VE	Valve insert (d) - INCH - ext. rinsing connection lower	EPDM HNBR	5670 038 793-041 5670 038 792-041	5670 051 793-041 5670 051 792-041	5670 064 793-041 5670 064 792-041	5670 076 793-041 5670 076 792-041	5670 101 793-041 5670 101 792-041	-	-
4	Bearing bush upper	PTFE	5622 050 006-053	5622 050 006-053	5622 065 006-053	5622 080 006-053	5622 100 006-053	5622 125 006-053	5622 150 006-040
5	Housing insert upper	AISI316L	5622 050 005-040	5622 050 005-040	5622 065 005-040	5622 080 005-040	5622 100 005-040	5622 125 005-040	5622 150 005-040
6	Piston lower -valve insert (a),(b),(c) Piston lower -valve insert (d)	AISI316L	5621 040 005-040 5676 040 023-040	5671 050 005-040 5676 050 023-040	5671 065 005-040 5676 065 023-040	5671 080 005-040 5676 080 023-040	5671 100 005-040 5676 100 023-040	5671 125 005-040 5676 125 023-040	5671 150 005-040 5676 150 023-040
7	Piston upper	AISI316L	5621 040 007-040	5621 050 007-040	5621 065 007-040	5621 080 007-040	5621 100 007-040	5621 125 007-040	5621 150 007-040
8	Piston plate upper	AISI316L	5621 050 006-040	5621 050 006-040	5621 065 006-040	5621 080 006-040	5621 100 006-040	5621 125 006-040	5621 150 006-040
9	Piston plate lower	AISI316L	5621 040 004-040	5621 050 004-040	5621 065 004-040	5621 080 004-040	5621 100 004-040	5621 125 004-040	5621 150 004-040
10	Disc	AISI304	8071 064 001-020	8071 064 001-020	8071 064 001-020	8071 084 001-020	8071 084 001-020	8071 105 001-020	8071 105 001-020
11	Hexagon nut	AISI304	8113 006 000-020	8113 006 000-020	8113 006 000-020	8113 008 000-020	8113 008 000-020	8113 010 000-020	8113 010 000-020
12	Plain bearing	XMS	8050 015 007-156	8050 015 007-156	8050 015 007-156	8050 020 007-156	8050 020 007-156	8050 020 007-156	8050 020 007-156
13	Split washer	AISI304	8140 006 001-020	8140 006 001-020	8140 006 001-020	8072 008 001-020	8072 008 001-020	-	-
14	Hexagon screw Disc DIN125	AISI304 AISI304	8106 008 016-020 -	8106 008 016-020 -	8106 008 016-020 -	8106 008 016-020 -	8106 008 016-020 -	8106 008 025-020 8071 084 001-020	8106 008 025-020 8071 084 001-020
15	Lantern -valve insert (a), (d) Lantern compl. -valve insert (b) Lantern compl. -valve insert (c)	AISI304 AISI304 AISI304	5624 040 008-021 5624 040 515-021 5624 040 517-021	5624 050 008-021 5624 050 515-021 5624 050 517-021	5624 065 008-021 5624 065 515-021 5624 065 517-021	5624 080 008-021 5624 080 515-021 5624 080 517-021	5624 100 008-021 5624 100 515-021 5624 100 517-021	5624 125 008-021 5624 125 515-021 5624 125 517-021	5624 150 008-021 5624 150 515-021 5624 150 517-021
16	Valve lift stop	AISI303	5622 040 009-220	5622 050 009-220	5622 065 009-220	5622 080 009-220	5622 100 009-220	5622 125 009-220	5622 150 009-220
17	Pneum. actuator	AISI304	5620 065 000-021	5620 065 000-021	5620 065 000-021	5620 100 000-021	5620 100 000-021	5620 150 000-021	5620 150 000-021
18	Position indication red	PVC	5622 100 058-151	5622 100 058-151	5622 100 058-151	5622 100 058-151	5622 100 058-151	5622 100 058-151	5622 100 058-151
19	O-Ring	NBR	2304 012 020-055	2304 012 020-055	2304 012 020-055	2304 012 020-055	2304 012 020-055	2304 012 020-055	2304 012 020-055
20	Screwed cap	AISI303	5622 100 071-220	5622 100 071-220	5622 100 071-220	5622 100 071-220	5622 100 071-220	5622 100 071-220	5622 100 071-220
21	Screwed socket	AISI303	5624 065 514-020	5624 065 514-020	5624 065 514-020	5624 100 514-020	5624 100 514-020	5624 150 514-020	5624 150 514-020
LA1	One-way restricter	-	8218 001 020-000	8218 001 020-000	8218 001 020-000	8218 001 020-000	8218 001 020-000	8218 001 020-000	8218 001 020-000
LA3	Rapid action hose coupling	-	8217 000 004-000	8217 000 004-000	8217 000 004-000	8217 000 004-000	8217 000 004-000	8217 000 004-000	8217 000 004-000

16.2 Seal kits - Double seat valve Type 567x, DN 40 - 150 / DN 1 - 4INCH

Item	Designation	Material	DN40 1½INCH	DN50 2INCH	DN65 2½INCH	DN80 3INCH	DN100 4INCH	DN125 -	DN150 -
	Seal kit (A) - Standard	EPDM	5670 040 739-000	5670 050 739-000	5670 065 739-000	5670 080 739-000	5670 100 739-000	5670 125 739-000	5670 150 739-000
	Seal kit (B) - rinsing connection upper	EPDM	5670 040 769-000	5670 050 769-000	5670 065 769-000	5670 080 769-000	5670 100 769-000	5670 125 769-000	5670 150 769-000
	Seal kit (C) - rinsing connection lower	EPDM	5670 040 799-000	5670 050 799-000	5670 065 799-000	5670 080 799-000	5670 100 799-000	5670 125 799-000	5670 150 799-000
D1	Seal (2x)	EPDM	5622 050 010-069	5622 050 010-069	5622 065 010-069	5622 080 010-069	5622 100 010-069	5622 125 010-069	5622 150 010-069
D2	O-Ring (4x)	EPDM	2304 069 026-159	2304 069 026-159	2304 082 026-159	2304 098 035-159	2304 117 035-159	2304 142 035-159	2304 177 035-170
D3	O-Ring	EPDM	2304 026 015-170	2304 026 015-170	2304 029 015-170	2304 042 020-170	2304 036 020-170	2304 036 020-170	2304 036 020-170
D4	Seal (2x)	EPDM	5621 050 010-084	5621 050 010-084	5621 065 010-084	5621 080 010-084	5621 100 010-084	2304 113 053-084	2304 133 053-159
D5	O-Ring	EPDM	2304 041 035-159	2304 041 035-159	2304 050 035-159	2304 066 035-159	2304 085 035-159	2304 111 035-084	2304 140 035-159
D6	O-Ring	EPDM	2304 038 018-170	2304 038 018-170	2304 048 020-170	2304 057 020-170	2304 076 020-170	2304 092 035-159	2304 108 035-170
D7	Headless pin	AISI316L	8112 006 050-040	8112 006 060-040	8112 006 085-040	8112 008 050-040	8112 008 085-040	8112 010 065-020	8112 010 090-040
D8	O-Ring	EPDM	2304 036 035-159	2304 036 035-159	2304 036 035-159	2304 041 035-159	2304 041 035-159	2304 041 035-159	2304 041 035-159
D9	O-Ring	EPDM	2304 047 035-159	2304 047 035-159	2304 057 035-159	2304 069 035-159	2304 092 035-159	2304 117 035-159	2304 142 035-159
D10	O-Ring	NBR	2304 042 025-055	2304 042 025-055	2304 042 025-055	2304 046 025-055	2304 046 025-055	2304 046 025-055	2304 046 025-055
D11	O-Ring (1x) (seal kit B) O-Ring (2x) (seal kit C)	EPDM	2304 014 020-170	2304 014 020-170	2304 014 020-170	2304 014 020-170	2304 016 020-170	2304 016 020-170	2304 016 020-170
D12	O-Ring (2x) (only seal kit C)	EPDM	-	2304 036 035-159	2304 054 035-159	2304 082 035-159	-	-	-
11	Hexagon nut	AISI304	8113 006 000-020	8113 006 000-020	8113 006 000-020	8113 008 000-020	8113 008 000-020	8113 010 000-020	8113 010 000-020

Item	Designation	Material	DN40 1½INCH	DN50 2INCH	DN65 2½INCH	DN80 3INCH	DN100 4INCH	DN125 -	DN150 -
	Seal kit (A) - Standard	HNBR	5670 040 729-000	5670 050 729-000	5670 065 729-000	5670 080 729-000	5670 100 729-000	5670 125 729-000	5670 150 729-000
	Seal kit (B) - rinsing connection upper	HNBR	5670 040 779-000	5670 050 779-000	5670 065 779-000	5670 080 779-000	5670 100 779-000	5670 125 779-000	5670 150 779-000
	Seal kit (C) - rinsing connection lower	HNBR	5670 040 798-000	5670 050 798-000	5670 065 798-000	5670 080 798-000	5670 100 798-000	5670 125 798-000	5670 150 798-000
D1	Seal (2x)	HNBR	5622 050 010-050	5622 050 010-050	5622 065 010-050	5622 080 010-050	5622 100 010-050	5622 125 010-050	5622 150 010-050
D2	O-Ring (4x)	HNBR	2304 069 026-050	2304 069 026-050	2304 082 026-050	2304 098 035-050	2304 117 035-050	2304 142 035-050	2304 177 035-050
D3	O-Ring	EPDM	2304 026 015-170	2304 026 015-170	2304 029 015-170	2304 042 020-170	2304 036 020-170	2304 036 020-170	2304 036 020-170
D4	Seal (2x)	HNBR	5621 050 010-157	5621 050 010-157	5621 065 010-157	5621 080 010-157	5621 100 010-157	2304 113 053-157	2304 133 053-157
D5	O-Ring	HNBR	2304 041 035-157	2304 041 035-157	2304 050 035-157	2304 066 035-157	2304 085 035-157	2304 111 035-157	2304 140 035-157
D6	O-Ring	EPDM	2304 038 018-170	2304 038 018-170	2304 048 020-170	2304 057 020-170	2304 076 020-170	2304 092 035-159	2304 108 035-170
D7	Headless pin	AISI316L	8112 006 050-040	8112 006 060-040	8112 006 085-040	8112 008 050-040	8112 008 085-040	8112 010 065-020	8112 010 090-040
D8	O-Ring	EPDM	2304 036 035-159	2304 036 035-159	2304 036 035-159	2304 041 035-159	2304 041 035-159	2304 041 035-157	2304 041 035-159
D9	O-Ring	EPDM	2304 047 035-159	2304 047 035-159	2304 057 035-159	2304 069 035-159	2304 092 035-159	2304 117 035-159	2304 142 035-159
D10	O-Ring	NBR	2304 042 025-055	2304 042 025-055	2304 042 025-055	2304 046 025-055	2304 046 025-055	2304 046 025-055	2304 046 025-055
D11	O-Ring (1x) (seal kit B) O-Ring (2x) (seal kit C)	EPDM	2304 014 020-170	2304 014 020-170	2304 014 020-170	2304 014 020-170	2304 016 020-170	2304 016 020-170	2304 016 020-170
D12	O-Ring (2x) (only seal kit C)	EPDM	-	2304 036 035-159	2304 054 035-159	2304 082 035-159	-	-	-
11	Hexagon nut	AISI304	8113 006 000-020	8113 006 000-020	8113 006 000-020	8113 008 000-020	8113 008 000-020	8113 010 000-020	8113 010 000-020



Declaration of incorporation

Translation of the original

Manufacturer / authorised representative:

KIESELMANN GmbH
Paul-Kieselmann-Str. 4-10
75438 Knittlingen
Germany

Authorised representative,
for compiling technical documents:

Achim Kauselmann
KIESELMANN GmbH
Paul-Kieselmann-Str. 4-10
75438 Knittlingen
Germany

Product name

pneum. Lift actuators
pneum. Rotary actuators
Ballvalves
Butterfly valves
Single seat valves
Flow control valves
Throttle valve
Overflow valve
Double seat valve
Bellow valves
Sampling valves
Two way valves
Tankdome fitting

Function

Stroke movement
Rotary movement
Media cutoff
Media cutoff
Media cutoff
Control of liquified media
Control of liquified media
Definition of fluid pressure
Media separation
Sampling of liquids
Sampling of liquids
Media cutoff
Prevention of overpressure and vacuum

The manufacturer hereby states that the above product is considered as an incomplete machine in the sense defined in the Directive 2006/42/EC on Machinery. The above product is exclusively intended to be installed into a machine or an incomplete machine. The said product does not yet conform to all the relevant requirements defined in the Directive on Machinery referred to above for this reason.

The specific technical documents listed in Appendix VII, Part B, have been prepared. The Authorized Agent empowered to compile technical documents may submit the relevant documents if such a request has been properly justified.

Commissioning of an incomplete machine may only be carried out if it has been determined that the respective machine into which the incomplete machine is to be installed conforms to the regulations set out in the Directive on Machinery referred to above.

The above product conforms to the requirements of the directives and harmonized standards specified below:

- DIN EN ISO 12100-1 Safety of machinery
- DIN EN ISO 12100-2 Safety of machinery

Knittlingen, 15. 04. 2011

Klaus Dohle
General Director