

Warren Pumps
FSXA 2300 Series
 Heavy-Duty, High Pressure Screw Pumps



Two-Screw Team



ברלין טכנולוגיות בע"מ
 שדרות גן רוהה 13, יבנה, 8122214
<http://www.berlintech.co.il/>
mail@berlintech.co.il
 טלפון: 073-7597171
 פקס: 08-6638120



FSXA 2300 Series Heavy-Duty, High Pressure Screw Pumps

- Capacities to 3500 GPM+
- Discharge pressures to 1400 PSI
- Viscosities from .5 cst

Advantages

- Very high efficiencies
- Rugged body and rotor design
- Excellent performance on both low and high viscosity fluids (.05 – 10,000 cst)
- Double helical timing gears minimize rotor wear by maintaining axial alignment, and also provide torque load capacities
- Long service intervals

Applications

- **Crude Oil Pipelines or Platforms** – transfer and gathering
- **Gas Turbine Fuel Pumps or Burner Feed Pumps** – fuel oils and naphtha
- **Petroleum Transport** – barge and tanker loading/unloading, tank farms

Options

- Iron or Cast Steel Casing
- Chrome Plated Bores
- Hard Fused Coating on Rotors
- Hardened Timing Gears
- External Seal Lubrication
- General Compliance with API676



Typical crude oil pipeline pump with natural gas engine drive.

Permanently Timed

Factory performed timing is easily repeated with Warren's method of gear and screw synchronization.

Back Pull Out

Rotor removes for inspection or repair without disturbing piping or driver. One-craft maintenance.

Bearings

Radial loading is handled by heavy-duty roller bearings at five locations that are sized to handle maximum loads. They are oil lubricated and are sealed off from the pumpage by internal mechanical seals, which are under suction pressure only. The heavy-duty double row thrust bearing locks the drive shaft in position axially. This is one of the only six bearing twin screw pump designs in the world and is a result of more than 50 years of experience in high pressure applications.

Hardened Steel Double Helical Timing Gears

Hardened steel double helical timing gears are used to prevent metal-to-metal contact between the meshed rotating screws. The clearance between the pumping screws results in longer pump life and higher average efficiencies over the life of the pump.

The double helical concept allows for multiple tooth engagement and maintains precision screw clearances. Both are features that commonly used spur-type gears cannot provide.

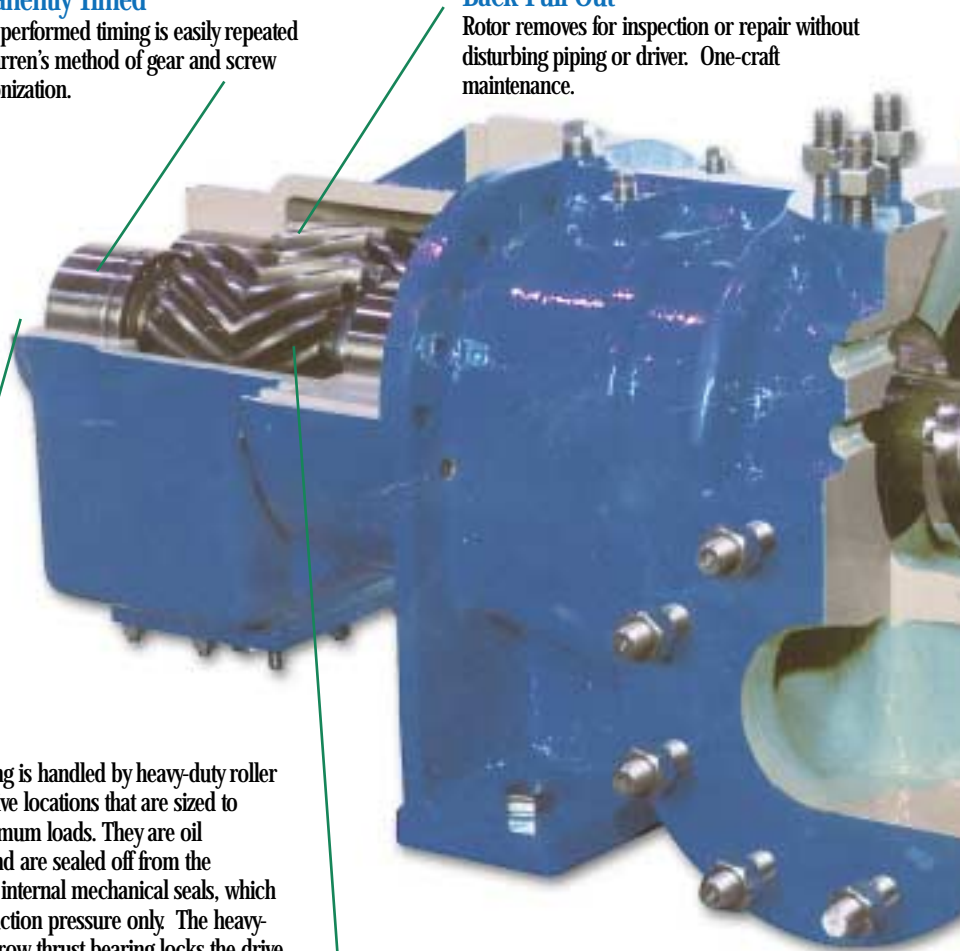



Body

The solid cast body is generously ribbed and has thick cross sections for pipeline pressures and rigidity. The suction flow passage is designed to provide a constant area from the flange opening to the screw entrance allowing for the best NPSH capabilities of any similarly sized pump.

Wear Protection

To insure long life in tough services, the critical pumping surfaces are coated. The body bore can be coated with an electrolytically applied industrial hard chrome. The screws can have a variety of OD coatings with hardness in excess of 60 (Rockwell C). Nitriding and other coating combinations are added features that, when combined with the chrome lined bore, have proven to be the best wear protection in the industry.

Integral Screw and Shaft

Each rotor is of an integral design, meaning that the entire screw and shaft is machined out of one piece of material, allowing for maximum rigidity and stiffness. This minimizes shaft deflection, an important consideration in high-pressure pumps.

High Efficiency Screw Profile

Having mastered the manufacture of pumping screws, the 2300 Series can come in a variety of screw pitches, and combined with the "QNS" screw profile offers the highest efficiency twin screw pump in the industry. This has been accomplished as a result of over 50 years of factory testing and field performance.

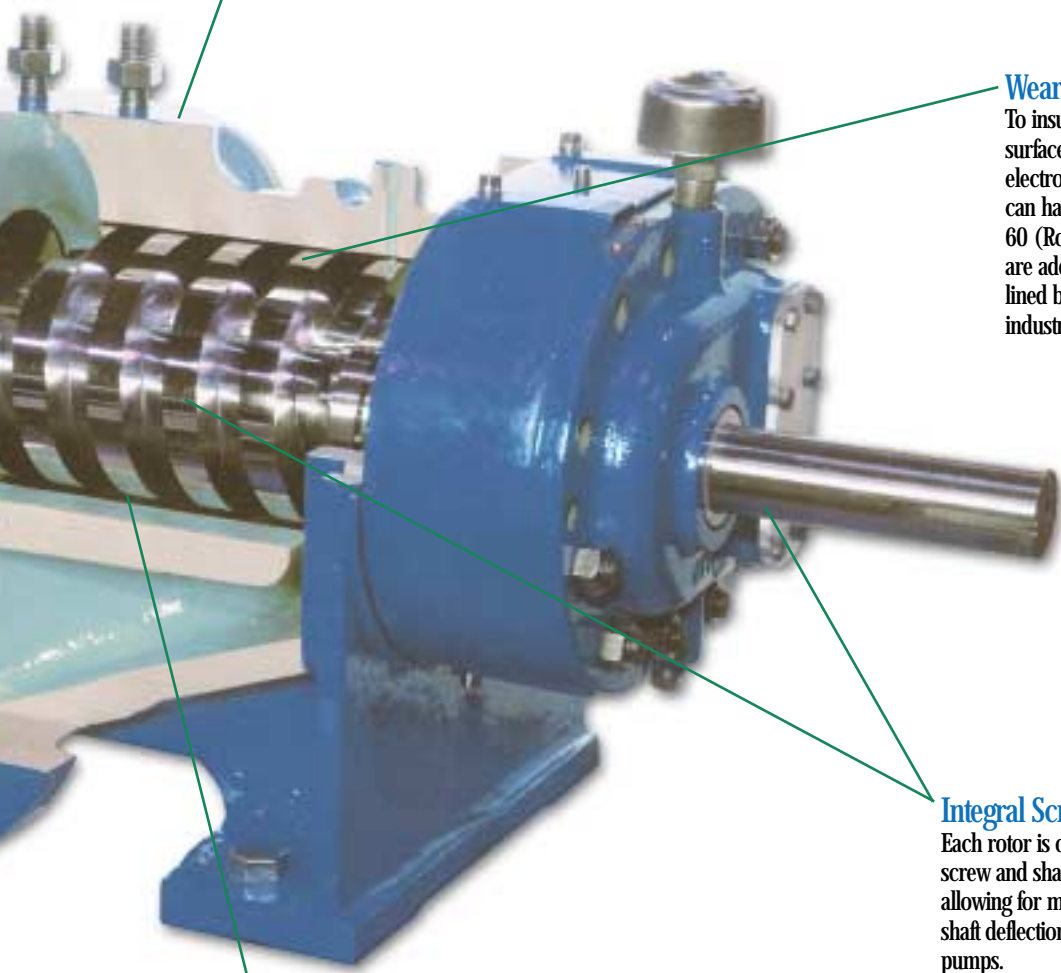

FSXA Quick Selection Chart

LEGEND

- Contact Warren
- FSXA-3830
- FSXA-2530
- FSXA-2030
- FSXA-1250
- FSXA-655
- FSXA-360

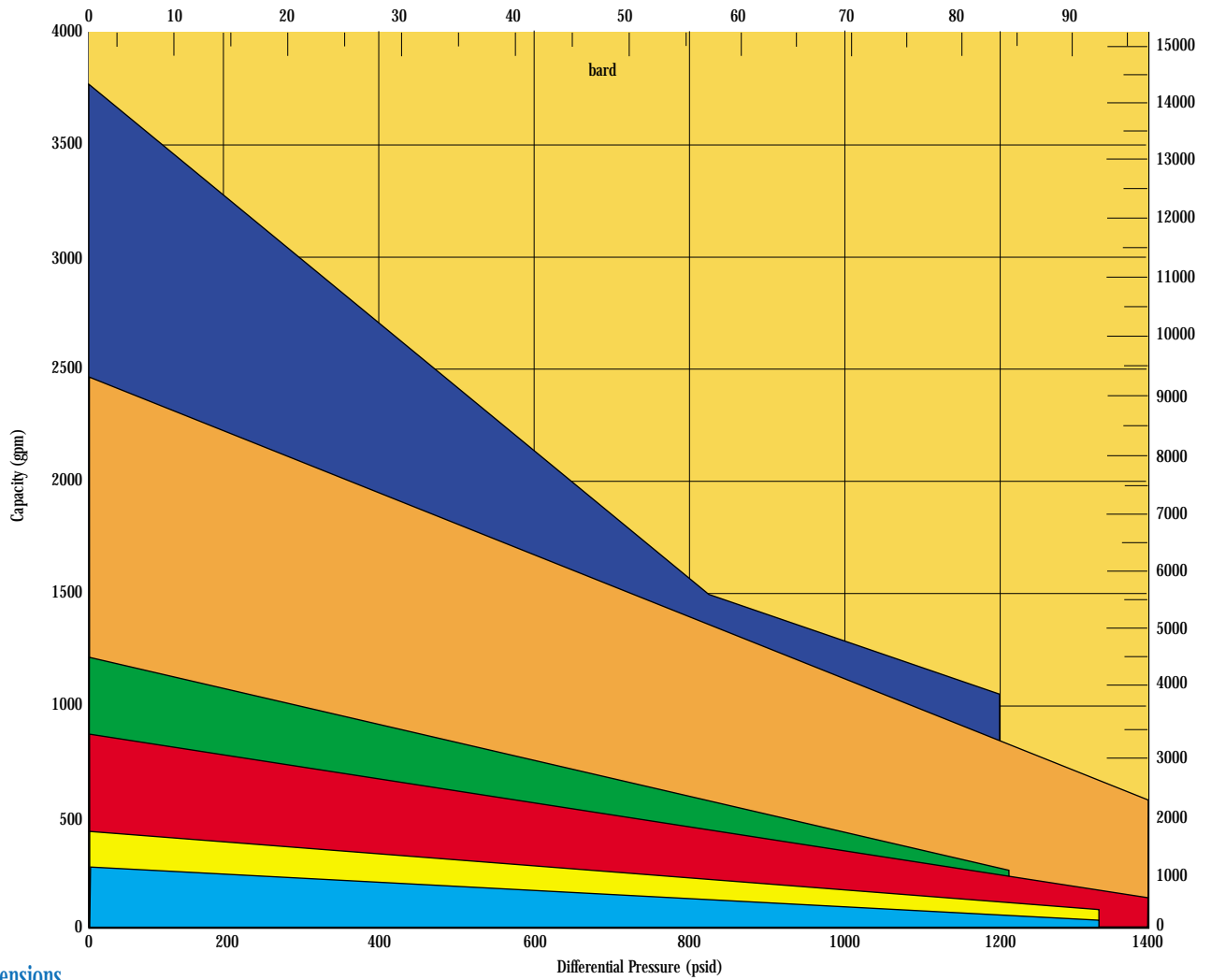

Approximate Dimensions

FSXA PUMP SIZE	SUCTION	DISCH.	MOTOR			C	CP	HA	HB	HC	HD	HG	HL	HM	HO	HT	X	Y	Z	HL1	PH	DH	W
			HP	RPM	FRAME																		
360*	2½" - 300#	2" - 600#	100	1750	405TS	35½"	37½"	21"	60¼"	77½"	13½"	3"	17½"	24¼"	17½"	5"	1½"	5½"	3¾"	26⅝"	10½"	*	N/A
655*	4" - 300#	3" - 600#	200	1750	447TS	43⅞"	47⅞"	23"	74¼"	96⅝"	15½"	4"	23⅞"	27⅞"	20¼"	5"	1⅞"	6¼"	5"	34⅞"	11½"	*	N/A
1250	6" - 300#	4" - 600#	250	1750	447TS	43⅞"	55¼"	23"	96½"	104⅞"	17"	4"	24⅞"	29⅞"	23"	5"	2¼"	8¾"	6¼"	37⅞"	13"	*	⅞"
2030	8" - 300#	6" - 600#	400	1750	5010S	58¼"	63⅝"	26"	122"	127⅞"	21½"	6"	28⅞"	36⅞"	28"	5"	2⅝"	9½"	7½"	43½"	15½"	*	1⅜"
2530	10" - 300#	8" - 600#	600	1150	6809L	75½"	78"	34"	150½"	158½"	24½"	6"	34¼"	43½"	32⅝"	5"	3⅞"	11⅞"	8¾"	53½"	18½"	*	1⅜"
3830	12" - 300#	10" - 600#	1000	1150	6811L	85½"	87⅞"	34"	166⅝"	177⅞"	29½"	8"	40"	48½"	38½"	5"	3¾"	12½"	10¼"	62"	21½"	*	5⅞"

* Pump Size #360 & #655 do not have Gear Housing Foot. Dimensions not to be used for construction purposes. * To be determined by customer.

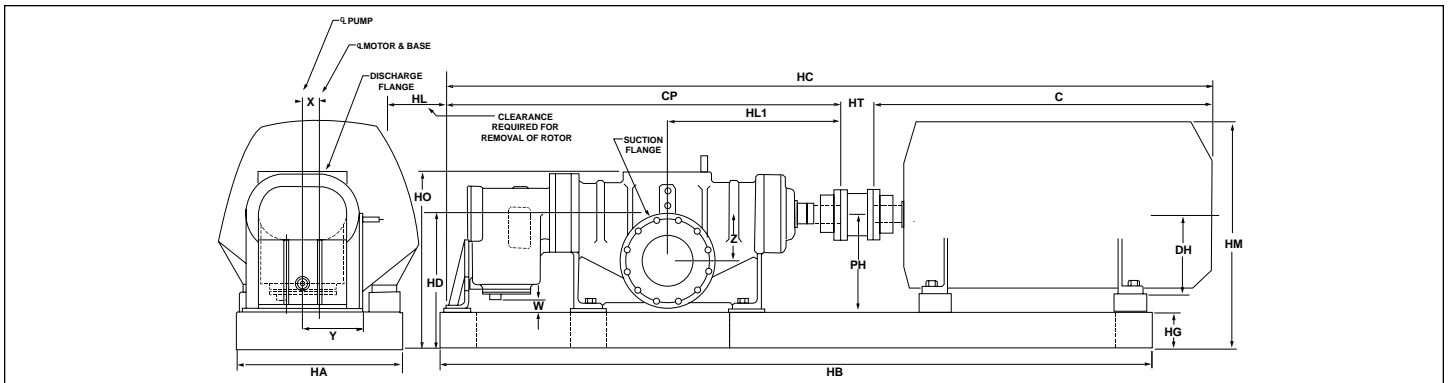

Proud Members Of



Warren Pumps Inc. • 82 Bridges Ave. • PO Box 969 • Warren, MA 01083-0969 USA
 Ph. 413-436-7711 • Fax 413-436-5605 • www.warrenpumps.com • email: warrensales@colfaxcorp.com