

# TECNICAPOMPE®

## Blender BL120-TEH

THE SOLUTION FOR MIXING SOLIDS AND LIQUIDS



**MIXER BL120-TEH-A**



**MIXER BL120-TEH-A  
WITH FEEDING PUMP**

### APPLICATIONS

The BL 120 is ideal for all liquids where powders are to be added and incorporated evenly (skimmed milk, ice-cream, oils, various foodstuffs, creamy desserts, etc.), enabling up to 20% solids to be incorporated. The flow of powder coming from the hopper (standard capacity 50 litres) and the flow of liquid remain completely separated as far as the inlet into the mixing chamber thereby preventing the formation of lumps or any obstruction which could clog up the feeder pipes.

The dosage of the dry components in the blender is regulated by a special throttle valve located at the output from the load hopper which allows the density of the blend to be regulated to specifications. The choice of materials and the attention to detail of every single component guarantee that the machine is completely reliable and suitable for processing foodstuffs.



ברלין טכנולוגיות בע"מ  
שדרות גן רוזה 13, יבנה, 8122214  
<http://www.berlintech.co.il/>  
[mail@berlintech.co.il](mailto:mail@berlintech.co.il)  
טלפון: 073-7597171  
פקס: 08-6638120

# Mixer BL120-TEH

## FUNCTIONS

The uniformity of the final density of the fluid is possible thanks to a permanent suction vortex inside the mixing chamber, constant during working operations. For this it is essential to maintain a uniform flow of the liquid. If it should prove necessary, taking into consideration the hydraulic circuit, an auxiliary pump (for example TCN or TEH model) can be fitted in front of the mixer that will stabilize and compensate the values of flow/height of the system.

## TECHNICAL CHARACTERISTICS OF THE MIXER

Capacity max solids: 1.200 kg/h  
 Capacity max liquids: 12.000 lt/h  
 Maximum height: 8 mt  
 Hopper standard: Capacity 50 litres, Incline 60°  
 Mixer power: 3 kW – 2 poles (2900 rpm)

## CHARACTERISTICS OF AUXILIARY PUMP

Standard model: TCN 55/04 semi-open impeller  
 Power: 3 kW – 4 poles (1450 rpm)

Model: TEH-B 190/04 open impeller, on request  
 in EHEDG  
 Power: 3 kW – 4 poles (1450 rpm)

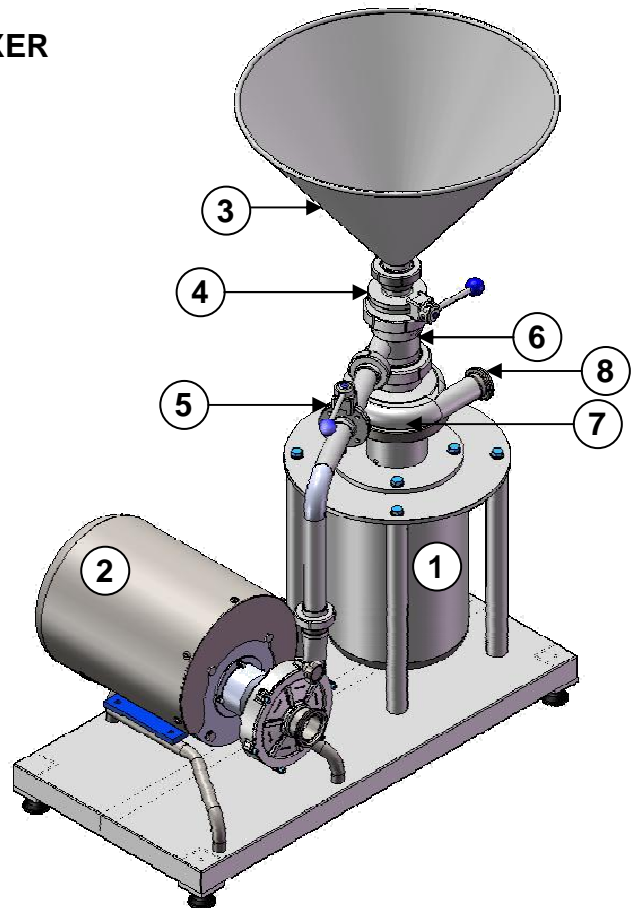

Description Base Elements Mixer With Auxiliary Pump	
1	Mixer
2	Auxiliary Pump
3	Hopper for Powder
4	Hopper Valve
5	Auxiliary Pump Valve
6	External Choke
7	Mixing Chamber
8	Mixed Product Outlet

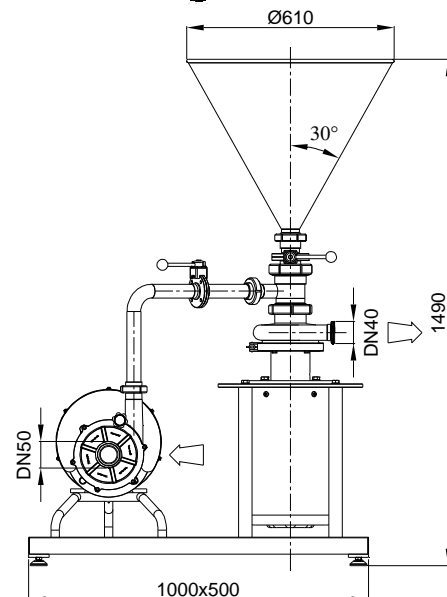
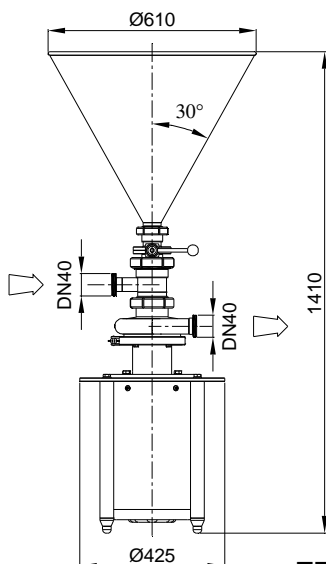

TECNICAPOMPE ZANIN Srl

Via Tretti, 6 – 36030 Fara Vicentino (VI) - ITALY

t. +39 0445 874883 – f. +39 0445 873866

www.tecnicapompe.com - info@tecnicapompe.it